

CURRENT TRANSFORMER  
**MODEL C**

**2.88" I.D.**

PAGE No 1-8

REV 14DEC00

**TERMINAL OPTION**

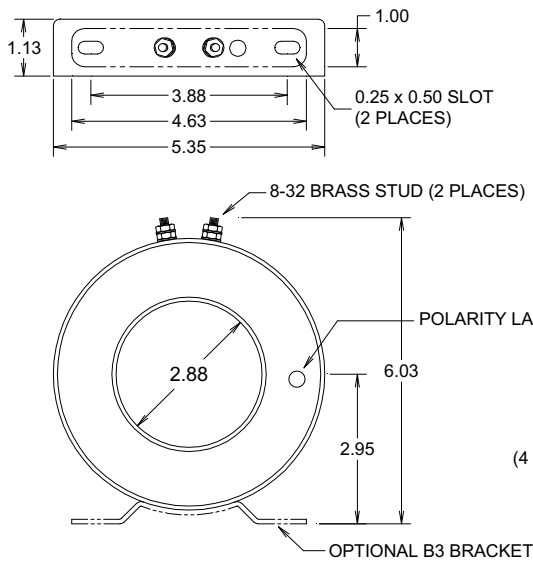

**LEAD WIRE OPTION**

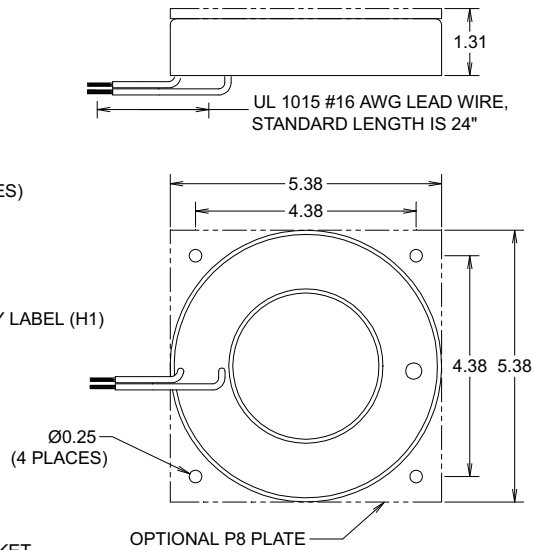

- NOTES  
 1). ALL DIMENSIONS IN INCHES  
 2). ALL DIMENSIONS REF ONLY

**Specifications**

Secondary sources 5 amps AC at rated F.S. primary current  
 Nominal operating frequency range is 50-400HZ  
 Thermal rating factor is 1.33 @ 30C for ratios up to 1600:5A, 1.15 @ 30C for ratios above 1600:5A  
 Insulation voltage class is 0.6KV BIL 10KV

For indoor applications only  
 Reference documents IEEE C57.13, UL1244, and IEC 44-1  
 Enclosure is glass-filled nylon, color is black  
 Optional plate is XX phenolic, optional bracket is aluminum

**Options, contact Factory for information**

UL and Canadian UL Recognized Component. File E100575  
 2.0, 5.0, and 10 VAC output at F.S. primary amperage. Other non-standard ratings also available.  
 1, 0.2, and 0.1 A output at F.S. primary amperage. Other non-standard ratings also available  
 8-32 Brass Stud Terminals or #16 AWG UL 1015 Lead Wires  
 Custom lead wire lengths and types  
 Thermal ratings above 1.33 for selected ratios.

Available with B1 and B31 brackets. See Bracket Data Section for dimensions.  
 Available with B54 bracket when ratio is above 500:5A. See Bracket Data Section for dimensions.  
 Center tap and custom multi tap winding arrangements

2.88" I.D.	CURRENT TRANSFORMER <b>MODEL C</b>
PAGE No 1-9	
REV 14DEC00	

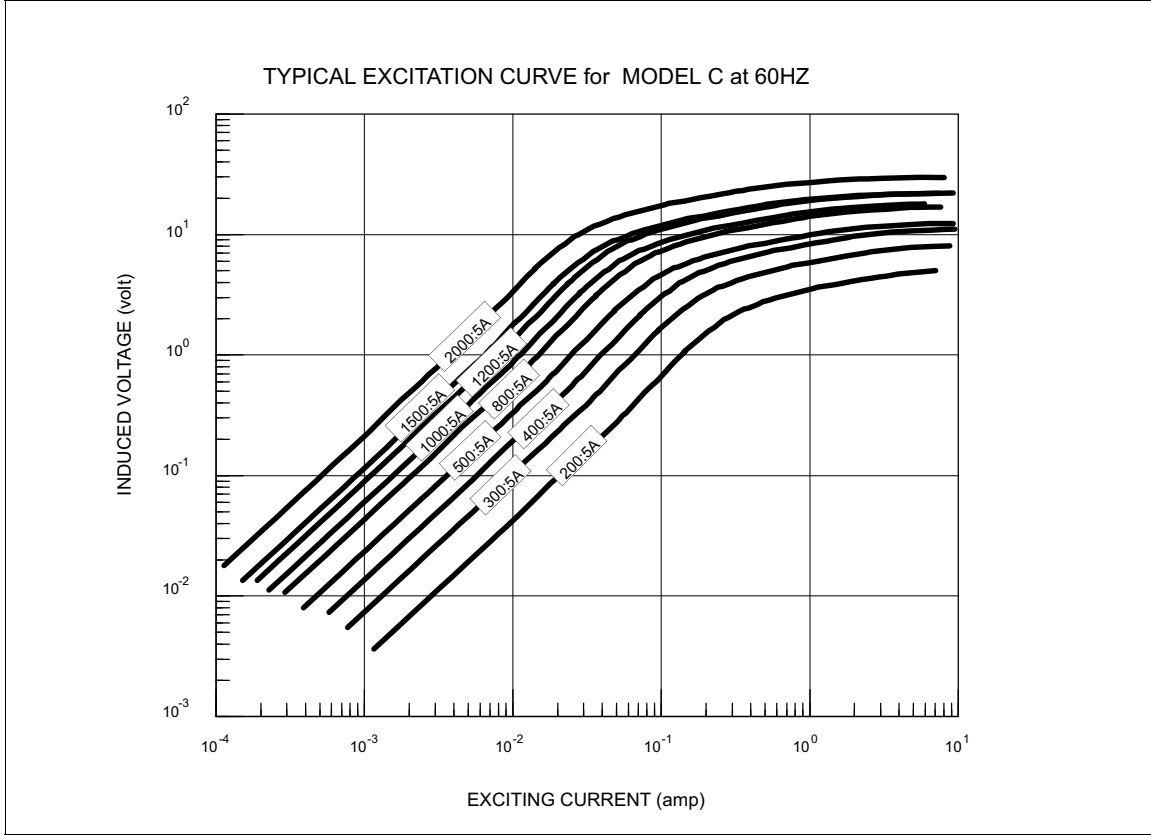

NUMBER *	RATIO	ACCURACY @ 60HZ, pf = 0.95		NOMINAL WINDING RESISTANCE (ohm)
		± %	BURDEN (VA)	
C-200-00-xxx	200:5A	1.5	2.0	0.06
C-250-00-xxx	250:5A	1.0	2.0	0.08
C-300-00-xxx	300:5A	1.0	3.0	0.09
C-400-00-xxx	400:5A	1.0	7.0	0.12
C-500-00-xxx	500:5A	1.0	10	0.14
C-600-00-xxx	600:5A	1.0	12	0.15
C-800-00-xxx	800:5A	1.0	20	0.20
C-1000-00-xxx	1000:5A	1.0	25	0.25
C-1200-00-xxx	1200:5A	1.0	30	0.30
C-1500-00-xxx	1500:5A	1.0	35	0.40
C-1600-00-xxx	1600:5A	1.0	30	0.43
C-1800-00-xxx	1800:5A	1.0	30	0.50
C-2000-00-xxx	2000:5A	1.0	35	0.60

\* "xxx" describes termination: "T" FOR BRASS STUDS, "Lyy" FOR LEAD WIRES (Where "yy" is the lead length in inches. For example, "L24" represents 24 inch long lead wires.)

CURRENT TRANSFORMER  
**MODEL CX**

**2.88" I.D.**

PAGE No 1-10

REV 14DEC00

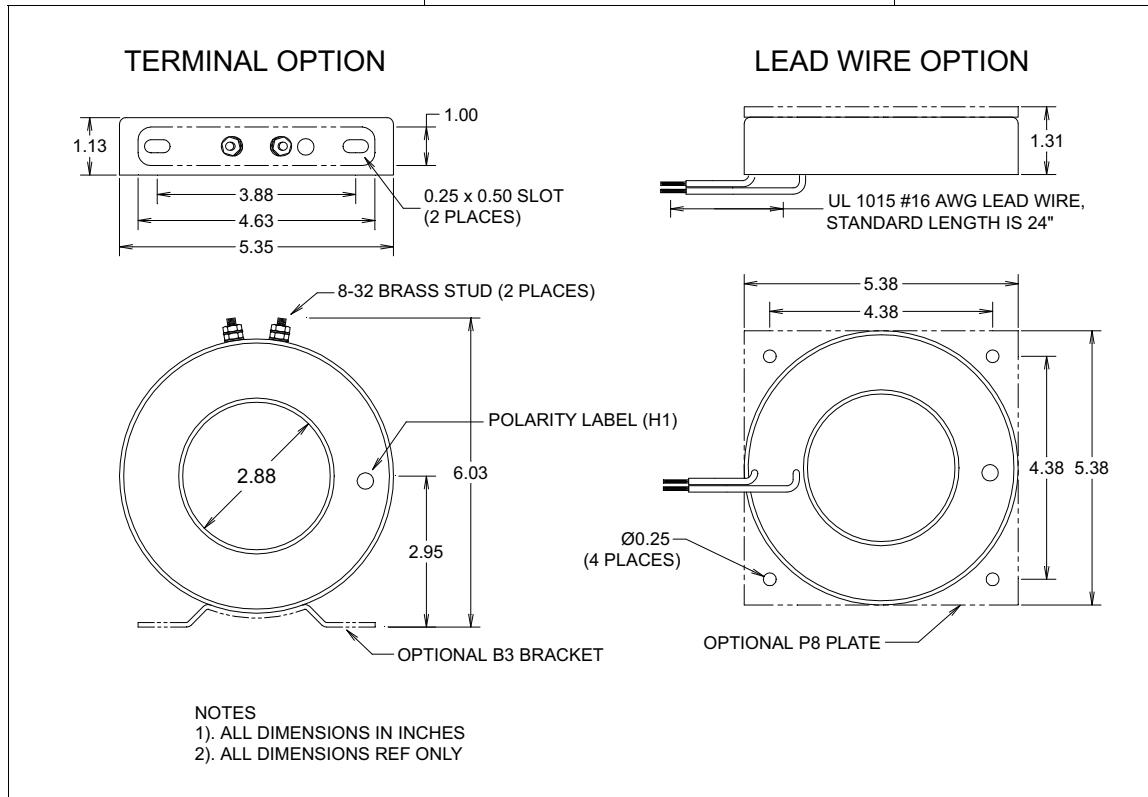

**Specifications**

Secondary sources 5 amps AC at rated F.S. primary current  
Nominal operating frequency range is 50-400HZ  
Thermal rating factor is 1.33 @ 30C for all ratios  
Insulation voltage class is 0.6KV BIL 10KV  
For indoor applications only

Reference documents IEEE C57.13, UL1244, and IEC 44-1  
Enclosure is glass-filled nylon, color is black  
Optional plate is XX phenolic, optional bracket is aluminum

**Options, contact Factory for information**

UL and Canadian UL Recognized Component. File E100575  
2.0, 5.0, and 10 VAC output at F.S. primary amperage. Other non-standard ratings also available.  
1, 0.2, and 0.1 A output at F.S. primary amperage. Other non-standard ratings also available  
8-32 Brass Stud Terminals or #16 AWG UL 1015 Lead Wires  
Custom lead wire lengths and types  
Thermal ratings above 1.33 for selected ratios.

Available with B1 and B31 brackets. See Bracket Data Section for dimensions.  
Available with B54 bracket when ratio is above 500:5A. See Bracket Data Section for dimensions.  
Center tap and custom multi tap winding arrangements

<b>2.88" I.D.</b>	<b>CURRENT TRANSFORMER MODEL CX</b>
PAGE No 1-11	
REV 14DEC00	

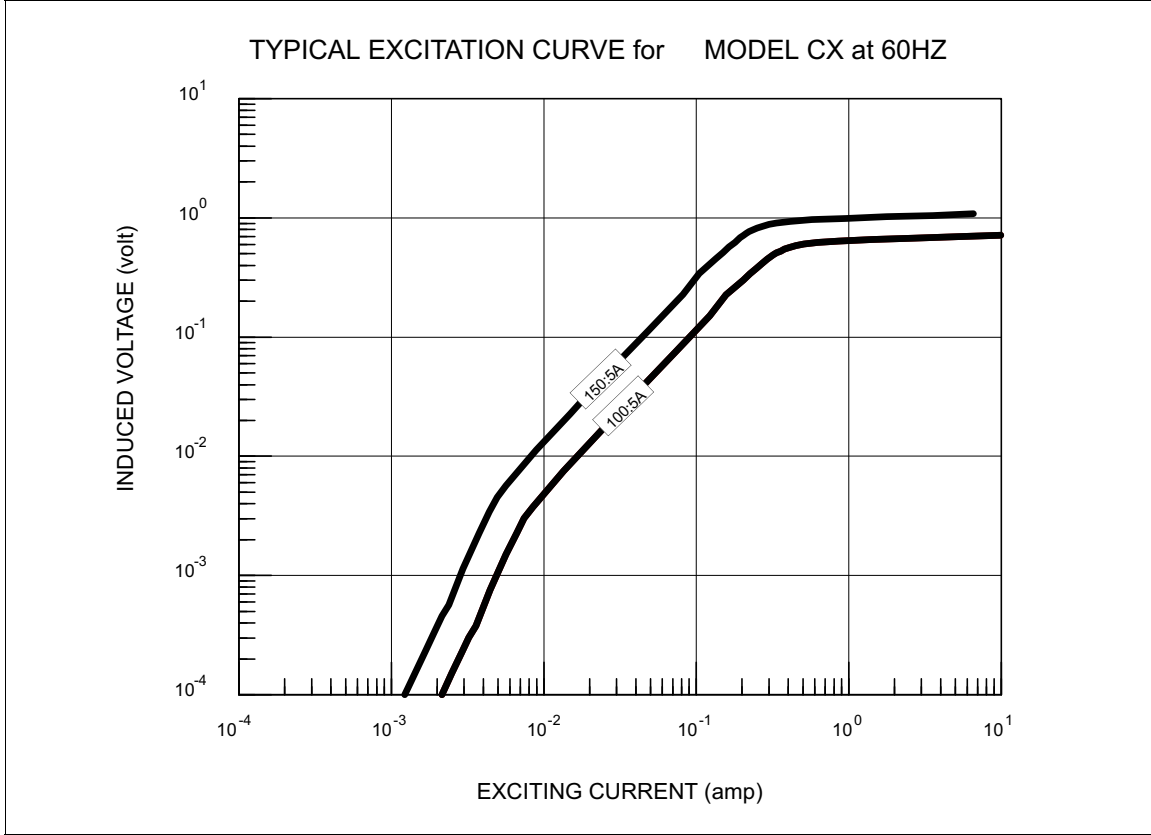

NUMBER *	RATIO	ACCURACY @ 60HZ, pf = 0.95		NOMINAL WINDING RESISTANCE (ohm)
		± %	BURDEN (VA)	
CX-100-00-xxx	100:5A	5.0	2.0	0.01
CX-150-00-xxx	150:5A	2.5	2.0	0.02

\* "xxx" describes termination: "T" FOR BRASS STUDS, "Lyyy" FOR LEAD WIRES (Where "yyy" is the lead length in inches. For example, "L24" represents 24 inch long lead wires.)